

# Autonics Refrigeration Temperature Controller TF3 SERIES INSTRUCTION MAUAL



Thank you for choosing our Autonics product. Please read the following safety considerations before use.

## Safety Considerations

Please observe all safety considerations for safe and proper product operation to avoid hazards. symbol represents caution due to special circumstances in which hazards may occur.

- Warning** Failure to follow these instructions may result in serious injury or death.
- Caution** Failure to follow these instructions may result in personal injury or product damage.

## Warning

- Fail-safe device must be installed when using the unit with machinery that may cause serious injury or substantial economic loss. (e.g. nuclear power control, medical equipment, ships, vehicles, railways, aircraft, combustion apparatus, safety equipment, crime/disaster prevention devices, etc.) Failure to follow this instruction may result in fire, personal injury, or economic loss.
- Install on a device panel to use. Failure to follow this instruction may result in electric shock or fire.
- Do not connect, repair, or inspect the unit while connected to a power source. Failure to follow this instruction may result in electric shock or fire.
- Check 'Connections' before wiring. Failure to follow this instruction may result in fire or explosion.
- Do not disassemble or modify the unit. Failure to follow this instruction may result in electric shock or fire.

## Caution

- When connecting the power, communication input and relay output, use AWG 28-12 cable and tighten the terminal screw with a tightening torque of 0.4N-m for the power, communication input terminal, and use AWG 28-12 cable and tighten the terminal screw with a tightening torque of 0.5N-m for the relay output. When connecting the sensor input cable without dedicated cable, use AWG 30-14 cable and tighten the terminal screw with a tightening torque of 0.2N-m. Failure to follow this instruction may result in fire or malfunction due to contact failure.
- Use the unit within the rated specifications. Failure to follow this instruction may result in fire or product damage.
- Use dry cloth to clean the unit, and do not use water or organic solvent. Failure to follow this instruction may result in electric shock or fire.
- Do not use the unit in the place where flammable/explosive/corrosive gas, humidity, direct sunlight, radiant heat, vibration, impact, or salinity may be present. Failure to follow this instruction may result in fire or explosion.
- Keep metal chip, dust, and wire residue from flowing into the unit. Failure to follow this instruction may result in fire or product damage.

## Ordering Information

TF 3 3 - 3 4 H - T	No-mark	No option
Option function <sup>※2</sup>	S	Synchronize defrost
	T	RS485 communication
	R <sup>※3</sup>	RTC (real time clock)
	A <sup>※3</sup>	RS485 communication+RTC (real time clock)
Compressor load capacity	G <sup>※1</sup>	Compressor 20A 1a contact
	A	Compressor 5A 1a contact
	H	Compressor 16A 1c contact
Power supply	1	24VAC 50/60Hz, 12-24VDC
	4	100-240VAC 50/60Hz
Output	1CH 1	Compressor output
	1CH, 2	Compressor+Defrost or Auxiliary (alarm/evaporator-fan) output
	3CH 3	Compressor+Defrost+Auxiliary (alarm/evaporator-fan) output
Number of input channels	1	1CH input (NTC or RTD) [temperature+digital input (DI)]
	3	3CH input (NTC) [inlet temperature+defrost temperature+outlet temperature or digital input (DI)]
Digits	3	999 (3 digit)
Item	TF	Refrigeration Temperature Controller

※1: Only for 1CH input, compressor output model (TF31-1□G).  
 ※2: Only for 3CH input model (TF33-□□□□). Option function is varied by compressor load capacity and contact.

Option function	Synchronize defrost function	RS485 communication	RTC function	RS485 communication+RTC function	No option
Compressor load capacity & contact	(TF33-□□A-S)	(TF33-□□A-T)	—	(TF33-□□A-A)	—
Compressor 5A 1a contact	●	●	—	●	—
Compressor 16A 1c contact	—	—	●	—	●

※3: Except compressor+defrost or auxiliary (alarm/evaporator-fan) output model (TF33-2□□□).  
 ※ Only for 3CH input, compressor+defrost+auxiliary (alarm/evaporator-fan) output model (TF33-3□□□) supports buzzer.  
 ※The above specifications are subject to change and some models may be discontinued without notice.  
 ※Be sure to follow cautions written in the instruction manual, user manual and the technical descriptions (catalog, homepage).

## Specifications

● TF3 Series	
Model	TF31-□□□□ TF33-□□□□
Number of channels	1CH 3CH
Power supply	AC power 100-240VAC~50/60Hz AC/DC power 24VAC~50/60Hz, 12-24VDC~
Allowable voltage range	90 to 110% of rated voltage
Power consumption	AC power Max. 8VA (100-240VAC~50/60Hz) AC/DC power Max. 5VA (24VAC~50/60Hz), Max. 3W (12-24VDC~)
Display method	7 Segment LED method (red)
Character size (W×H)	9.4×19.3mm
Input type	NTC 5kΩ/10kΩ RTD DP100Ω
Sampling period	500ms
Display accuracy	-At room temp. (23°C±5°C): ±1°C±1 digit -Out of room temp. range: ±2°C±1 digit
Control	Compressor (COMP) 250VAC~5A, 30VDC~5A, 1a / 250VAC~16A, 24VDC~16A, 1c / 250VAC~20A 1a
output	Defrost (DEF) 250VAC~10A, 24VDC~10A, 1a Auxiliary (AUX) 250VAC~5A, 30VDC~5A, 1a
Communication output	— RS485 communication output (Modbus RTU)
Digital input	Contact input: ON Max. 1kΩ, OFF Min. 100kΩ No contact input: ON residual voltage: Max. 1V, OFF leakage current: Max. 1mA, outflow current: 4μA
Control method	ON/OFF control
Hysteresis	0.5 to 5.0°C, 2 to 10°F variable
Relay life	Compressor (COMP) 5A 1a Mechanical: 5,000,000 operations, Electrical: 50,000 operations (250VAC 5A) 16A 1c Mechanical: 20,000,000 operations, Electrical: 30,000 operations (250VAC 16A) 20A 1a Mechanical: 10,000,000 operations, Electrical: 100,000 operations (250VAC 20A)
cycle	Defrost (DEF) Mechanical: 20,000,000 operations, Electrical: 100,000 operations (250VAC 10A) Auxiliary (AUX) Mechanical: 5,000,000 operations, Electrical: 50,000 operations (250VAC 5A)
Memory retention	Approx. 10 years (non-volatile memory method)
Insulation resistance	Min. 100MΩ (at 500VDC megger)
Dielectric strength	AC power 3000VAC 50/60Hz for 1 min (between all terminals and case, power and input circuit) AC/DC power 1000VAC 50/60Hz for 1 min (between all terminals and case, power and input circuit)
Noise resistance	Square-wave noise by the noise simulator (pulse width: 1μs) ±2kV R-phase and S-phase
Vibration	1.5mm amplitude at frequency of 10 to 55Hz (for 1 min) in each X, Y, Z direction for 2 hours
Environment	Ambient temp. -10 to 50°C, storage: -20 to 60°C Ambient humi. 35 to 85%RH, storage: 35 to 85%RH
Accessories	Bracket: 2, NTC sensor (5kΩ): 1
Protection structure	IP65 (front case)
Approval	CE, RoHS, etc.
Weight <sup>※1</sup>	Approx. 207g (approx. 105g)

● Remote display unit [TFD, sold separately]	
Model	TFD-3 TFD-5
Power supply	3.3VDC
Power consumption	Max. 1W
Display method	7 Segment LED method (red)
Comm. method	Serial (TTL Level), Half duplex
Comm. cycle	100ms
Cable	Ø2.5mm, 3m Ø2.5mm, 5m
Weight <sup>※1</sup>	Approx. 77g (approx. 48g)

※1: The weight includes packaging. The weight in parentheses is for unit only. The weight is varied by model option.  
 ※Environment resistance is rated at no freezing or condensation.

## Part Description

- Present value (PV) display component (red):** RUN mode: Displays present value (PV). Setting mode: Displays parameter and setting value.
- Deviation indicator (▲: green, ▼: red):** Displays deviation of present value (PV) based on setting value (SV).
- Compressor (COMP) output indicator (green):** Turns ON for compressor output. In case of compressor protection operation and output does not turn ON, it flashes. When operating compressor continuously, it turns ON for 2 sec, and turns OFF for 1 sec.

PV deviation temperature	Deviation display
More than 1.8°C	▲ indicator turns ON
Within ±1.8°C	■ indicator turns ON
Less than -1.8°C	▼ indicator turns ON

- Defrost (DEF) output indicator (green):** Turns ON for defrost output. Flashes for defrost delay operation. Turns ON for 2 sec and OFF for 1 sec for manual defrost or Power ON defrost.
- Evaporator-fan (FAN) output indicator (green):** Turns ON for evaporator-fan output. Flashes for delay operation of evaporator-fan output.
- Auxiliary (AUX) output indicator (green):** Turns ON for alarm output. Flashes for delay operation of alarm output.
- Unit indicator (red):** Displays temperature unit [unit] of parameter 1 group.
- (MODE) key:** Used for entering parameter setting group, returning RUN mode, moving parameter or saving SV.
- (AUX) key:** Used for entering SV setting group or changing setting value. Hold the key over 3 sec to select active/inactive auxiliary output in RUN mode.
- (DEF) key:** Used for entering SV setting group or changing setting value. Hold the key over 3 sec to execute/stop manual defrost in RUN mode.
- (COMP) key:** Used for entering SV setting group, changing setting value, moving digits. Hold the key over 3 sec to active/inactive compressor output in RUN mode. When buzzer alarm occurs, press the key once to stop the sound. (Only for 3CH input, compressor+defrost+auxiliary (alarm/evaporator-fan) output model (TF33-3□□□) supports buzzer. Buzzer [buzzer] of parameter 1 group is set as [on].)
- Data loader port:** It is for displaying TF3 data at remote display unit (TFD) by connecting phone-jack. In other case, for connecting Autonics SCM-US (USB/Serial converter, sold separately), it is a PC loader port of serial communication for parameter setting by PC.

## Input Type and Temperature Range

Input type	Decimal point	Display method	Temperature range (°C)	Temperature range (°F)
Thermistor (NTC)	1	n5H	-40 to 99	-40 to 212
	0.1	n5L	-40 to -20 -19.9 to 99.9	-40 to -20 -19.9 to 99.9
	1	n1H	-40 to 99	-40 to 212
	0.1	n1L	-40 to -20 -19.9 to 99.9	-40 to -20 -19.9 to 99.9
RTD <sup>※1</sup>	1	dPH	-99 to 99	-148 to 212
	0.1	dPL	-99 to -20 -19.9 to 99.9 <sup>※2</sup>	-148 to 212

※TF3 Series displays only 3 digits. If PV decimal number of shaded temperature range is out of 3 digit, TF3 does not display the numbers below decimal point. You can check it at the comprehensive device management program (DAQMaster) by communicating via PC.  
 ※1: Only for 1CH input model (TF31-□□□□).  
 ※2: If PV with "-" sign is over 3 digits (e.g.: -99.9), the numbers below decimal point does not display. You can check it at the comprehensive device management program (DAQMaster) by communicating via PC.

## Connections

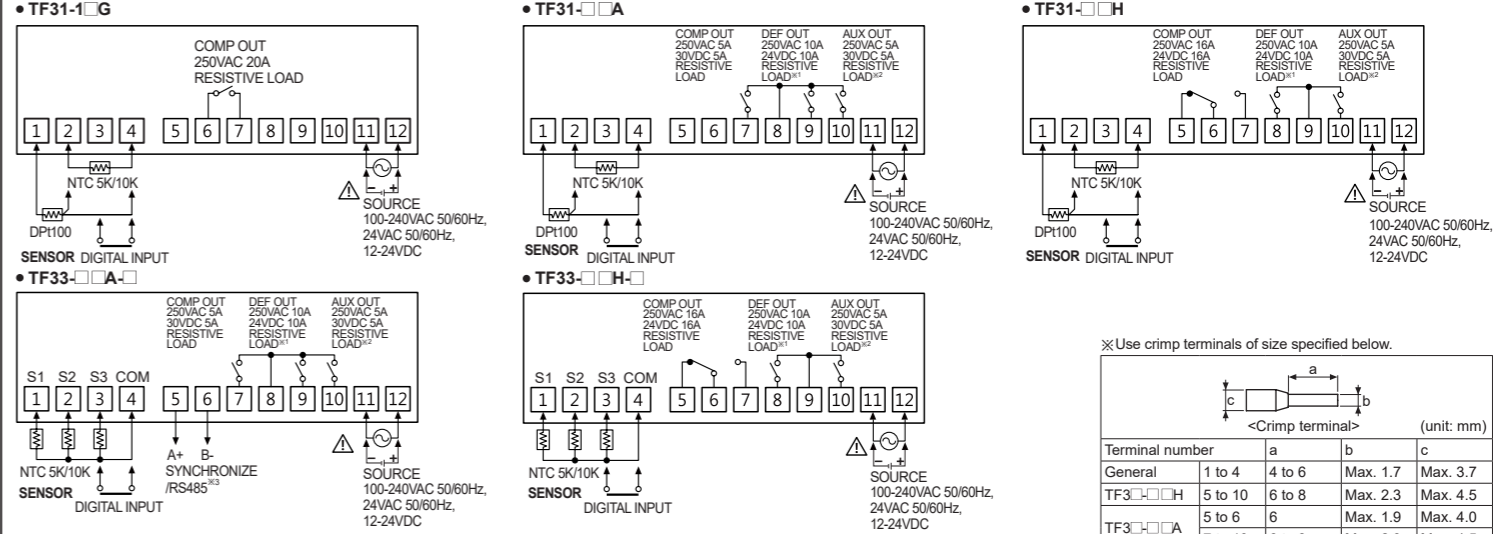

※1: Only for compressor+defrost or auxiliary (alarm/evaporator-fan) output model (TF31-1□□□), compressor+defrost+auxiliary (alarm/evaporator-fan) output model (TF33-3□□□).  
 ※2: Only for compressor+defrost+auxiliary (alarm/evaporator-fan) output model (TF33-3□□□).  
 ※3: Only for synchronize defrost function model (TF33-□□□□-S), or RS485 communication model (TF33-□□□□-T/A).

## Dimensions

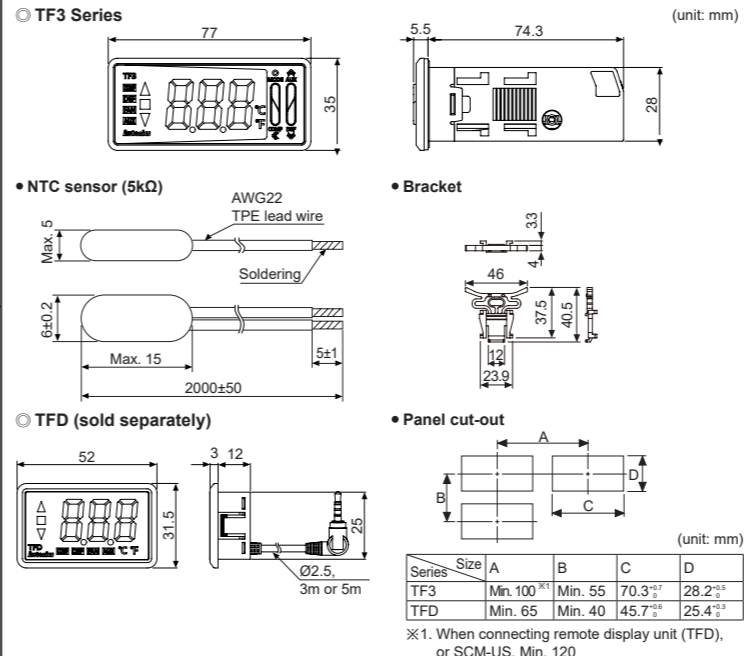

## Remote Display Unit (TFD) [sold separately]

Remote display unit (TFD) displays current temperature or output status of TF3 at remote place. TFD cable is TFD-3: 3m, TFD-5: 5m. Connect the phone-jack of remote display unit (TFD) to the data loader port of TF3. This unit is dedicated for PC, PLC, etc. and it does not directly communicate with upper devices (PC, PLC, etc.). If TFD communication with TF3 error occurs, TFD flashes display component for 1 sec. Check the connection with TF3.

※When connecting TFD to the data loader port of TF3, you cannot connect Autonics SCM-US (USB to Serial converter, sold separately) for communication. Use SCM-US48II(USB to RS485 converter, sold separately), SCM-38II(RS232C to RS485 converter, sold separately).

## SV Settings

You can set the temperature to control with in RUN mode to enter into SV setting mode. Set range is within SV low-limit value [L 5u] to SV high-limit value [H 5u]. E.g.) In case of changing SV from 19°C to 10°C

- Press any key among in RUN mode to enter into SV setting mode. Last digit (10<sup>th</sup> digit) on SV display part flashes.
- Press key to move digit. (10<sup>th</sup> → 10<sup>1st</sup> → 10<sup>2nd</sup> → 10<sup>3rd</sup> → 10<sup>4th</sup>)
- Press key to raise or lower the set value. (9 → 0)
- Press (MODE) key to save the set value. If there is no additional key operations in 3 sec, the changed SV is automatically saved.

## Comprehensive Device Management Program [DAQMaster]

DAQMaster is comprehensive device management program. It is available for parameter setting, monitoring, and user parameter group setting, parameter mask setting for only TF3 Series. DAQMaster can be downloaded from our web site at [www.autonics.com](http://www.autonics.com).

Item	Minimum specifications
System	IBM PC compatible computer with Pentium III or above
Operations	Windows 98/NT/XP/Mista/7/8/10
Memory	256MB+
Hard disk	1GB+ of available hard disk space
VGA	Resolution: 1024×768 or higher
Others	RS232C serial port (9-pin), USB port

## Parameter Mask

This function is able to hide unnecessary parameters to user environment or less frequently used parameters in parameter group. You can set this in the comprehensive device management program (DAQMaster). Masked parameters are only not displayed. The setting value of masked parameters are applied. For more information, refer to DAQMaster user manual. Visit our web site ([www.autonics.com](http://www.autonics.com)) to download DAQMaster program and the user manual.

Before applying mask: ...

After applying mask: ...

The above is masking input sensor 3 selection [53], temperature unit [unit] of parameter 1 group for 3CH input model (TF33-□□□□).

## Parameter User Group [PRU]

This function is able to set the frequently used parameters to the user parameter group. You can quickly and easily set parameter settings. User parameter group can have up to 30 parameters in the comprehensive device management program (DAQMaster). For more information, refer to the DAQMaster user manual. Visit our web site ([www.autonics.com](http://www.autonics.com)) to download the DAQMaster program and the user manual.

**RUN mode**

The above is setting user parameter group in the DAQMaster with delay display period [d5t] of parameter 1 group, hysteresis [HYS], night mode hysteresis [nHY] of parameter 2 group, defrost method [dEF], defrost time [dEt] of parameter 3 group, alarm output hysteresis [RHYS] of parameter 4 group.

## Virtual Temperature Rate [vtr]

(only for 3CH input model: TF33-□□□□)

In case of 3CH input model (TF33-□□□□), input sensor 3 selection [53] of parameter 1 group is set as outlet temperature [t 5]. You can set virtual temperature rate. If the temperature of inlet and outlet is significantly different at freezer, virtual temperature helps to control temperature efficiently. Virtual temperature is designated by the rate of input sensor 1 (inlet temperature) and input sensor 3 (outlet temperature). There is virtual temperature calculation formula.

$$\text{Virtual temperature (PV)} = \frac{[(100 - \text{virtual temperature rate}) \times \text{input sensor 1 temperature}] + [\text{virtual temperature rate} \times \text{input sensor 2 temperature}]}{100}$$

If virtual temperature rate [vtr] is set as [0], virtual temperature (PV) = input sensor 1. If virtual temperature rate [vtr] is set as [100], virtual temperature (PV) = input sensor 3. E.g.) If inlet temperature of input sensor 1 is 0°C, and outlet temperature of input sensor 3 is 10°C, set virtual temperature rate [vtr] as [50] and virtual temperature is 5°C to control temperature.

$$5 = \frac{[(100 - 50) \times 0] + [50 \times 10]}{100}$$

Setting range of virtual temperature rate: 0 to 100 (%)

## Display Selection [dPE]

(only for 3CH input model: TF33-□□□□)

You can select input sensor to display at present value (PV) display component in RUN mode.

Parameter	Description
51	Displays PV of input sensor 1 (inlet temperature).
52	Displays PV of input sensor 2 (defrost temperature).
53	Displays PV of input sensor 3 (outlet temperature).
u5	Displays virtual temperature.

